

## Swivel Clamp Connectors

Aluminum, Split Assembly

### SPECIFICATION

#### Type

- Type **OZ**: Without centering step

#### Identification No.

No. **2**: With 2 stainless steel socket cap screws DIN 912

Aluminum

- Powder coated

Black, RAL 9005, textured finish **SW**

- Plain, matte shot-blasted **BL**

Socket cap screws DIN 912

Stainless Steel AISI 304

Hex nuts DIN 985

Stainless Steel AISI 304

Self-locking via polyamide ring



### INFORMATION

The clamping bore of swivel clamp connectors GN 279 is not machined and designed for construction tubes GN 990 (see page 1902) or DIN 2391, DIN 2395 and DIN 2462.

The versions with square bores are also suitable for **profile systems**.

At the screw locations **z**, the socket cap screws reduce the bore cross-section for clamping. For clamping without tools, the socket cap screws can be replaced by the adjustable hand levers GN 911 (see page 1874) listed in the table as accessories.

Two swivel clamp connectors GN 279 can be combined to swivel clamp connector joints GN 289 (see page 1870).

Swivel clamp connectors GN 279 can be combined with swivel clamp connectors GN 272 (see page 1848), GN 274 (see page 1850) or GN 276 (see page 1852) to swivel clamp connector joints.

### ACCESSORY

- Adjustable Hand Levers GN 911 (see page 1874)

### TECHNICAL INFORMATION

- Stainless Steel Characteristics (see page A26)

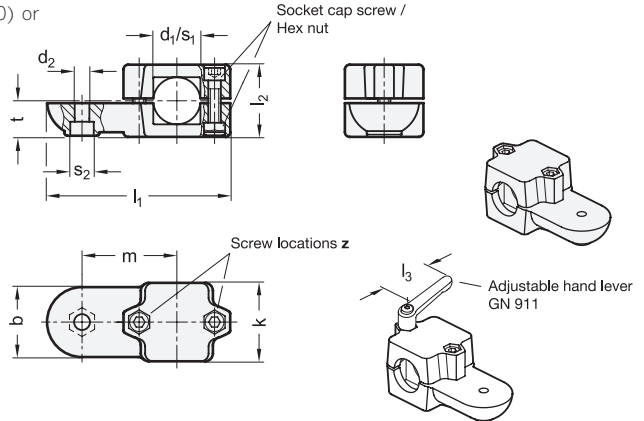

\* Complete with

**SW** **BL**  
RAL9005 Plain

### GN 279-B

Description	d <sub>1</sub>	b	d <sub>2</sub>	k Clamping length	l <sub>1</sub>	l <sub>2</sub>	m	s <sub>2</sub>	t	z Screw locations	Accessory Recom. hand lever GN 911 for z l <sub>3</sub>	⚖
GN 279-B40-OZ-2-*	B 40	65	10.5	76	166.5	70	85	17	35	M10-60	78   92	970
GN 279-B42-OZ-2-*	B 42	65	10.5	76	166.5	70	85	17	35	M10-60	78   92	964
GN 279-B45-OZ-2-*	B 45	65	10.5	76	166.5	70	85	17	35	M10-60	78   92	958
GN 279-B48-OZ-2-*	B 48	65	10.5	76	166.5	70	85	17	35	M10-60	78   92	940
GN 279-B50-OZ-2-*	B 50	65	10.5	76	166.5	70	85	17	35	M10-60	78   92	800

### GN 279-S

Description	s <sub>1</sub>	b	d <sub>2</sub>	k Clamping length	l <sub>1</sub>	l <sub>2</sub>	m	s <sub>2</sub>	t	z Screw locations	Accessory Recom. hand lever GN 911 for z l <sub>3</sub>	⚖
GN 279-V40-OZ-2-*	V 40	65	10.5	76	166.5	70	85	17	35	M10-60	78   92	957
GN 279-V45-OZ-2-*	V 45	65	10.5	76	166.5	70	85	17	35	M10-60	78   92	914
GN 279-V50-OZ-2-*	V 50	65	10.5	76	166.5	70	85	17	35	M10-60	78   92	868

Weight SW